

Vanity Case Instructions

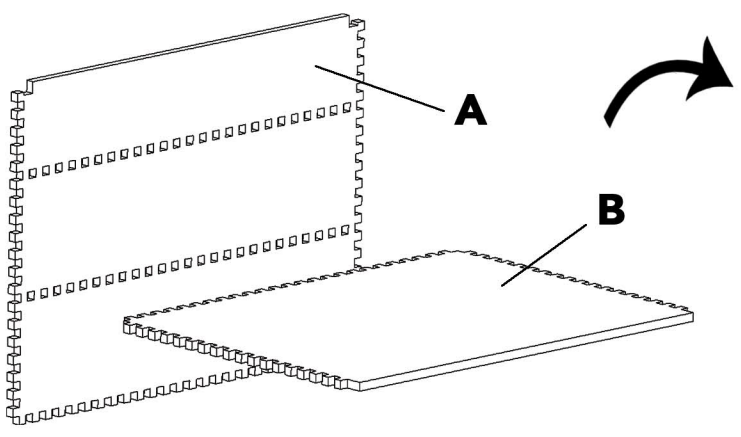

1. Slot piece B into piece A.

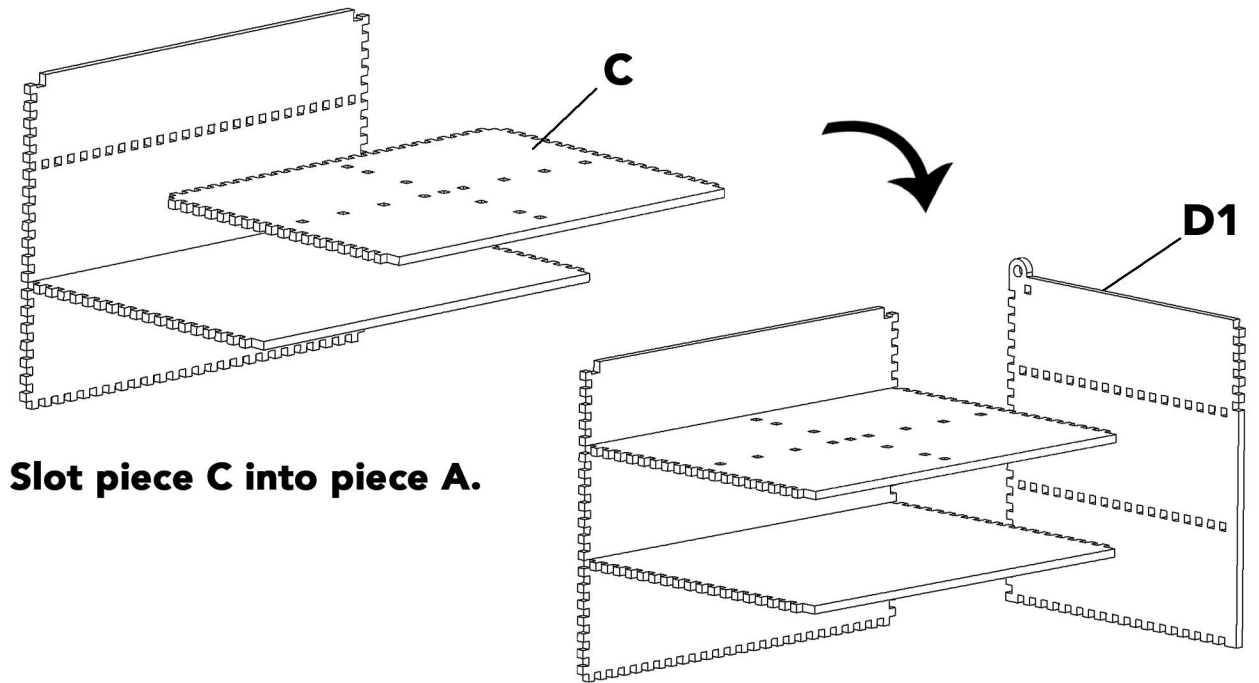

2. Slot piece C into piece A.

3. Slot piece D1 onto pieces A, B & C and put to one side.

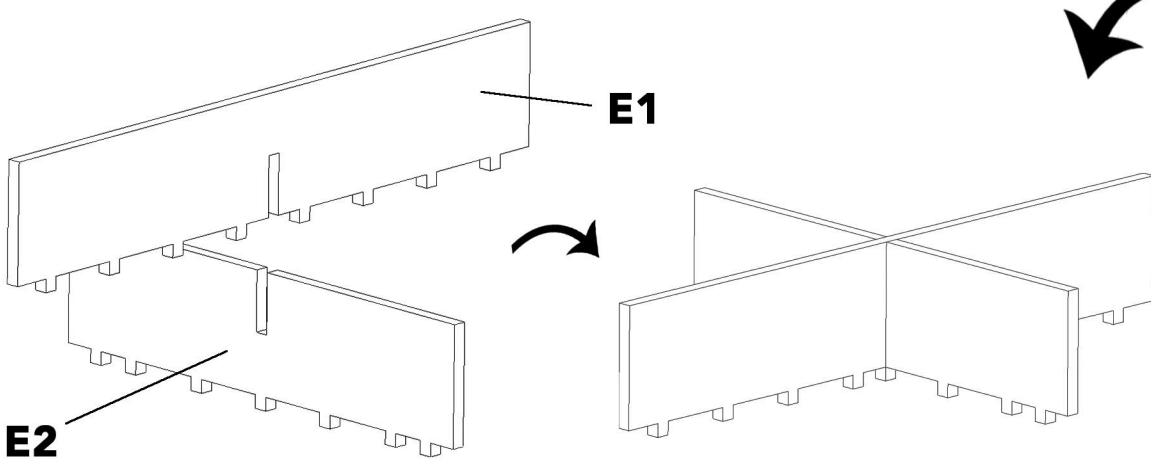

4. Slot pieces E1 and E2 together.

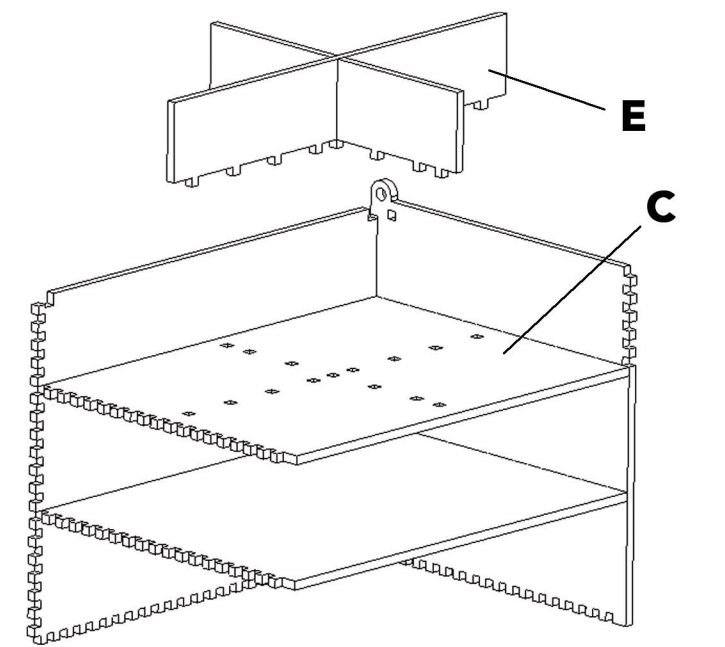

5. Slot pieces E into piece C.

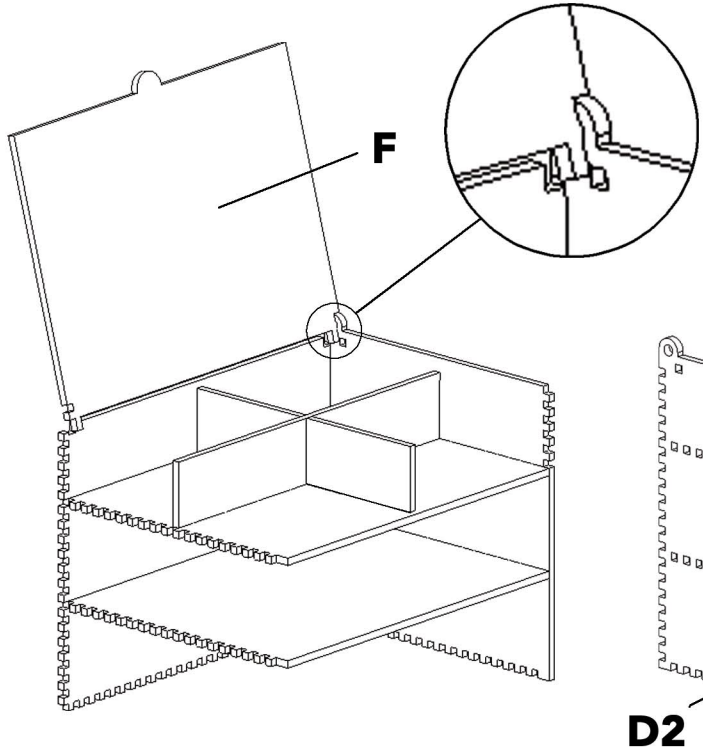

6. Slot piece F into the hole in piece D1 and carefully slot piece D2 onto the other end, ensuring piece F also goes through the hole in piece D2.
Note: Ensure that any engraved design is facing the correct way.

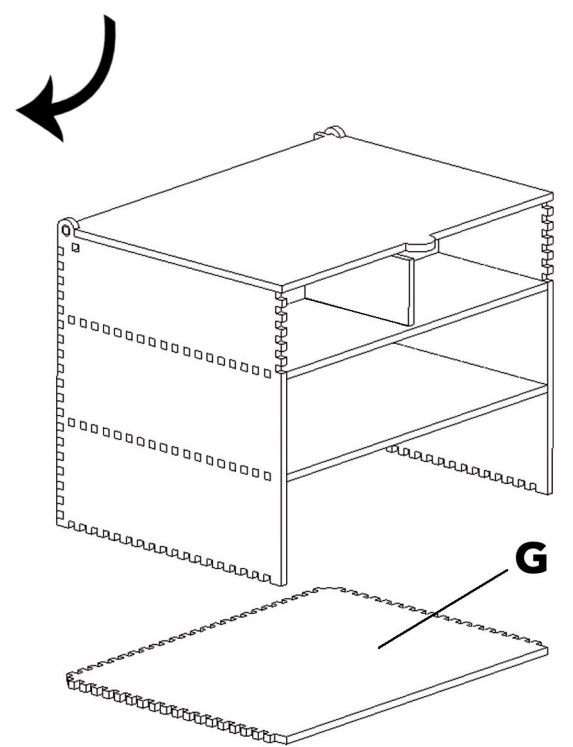

7. Slot piece G onto pieces A & D.

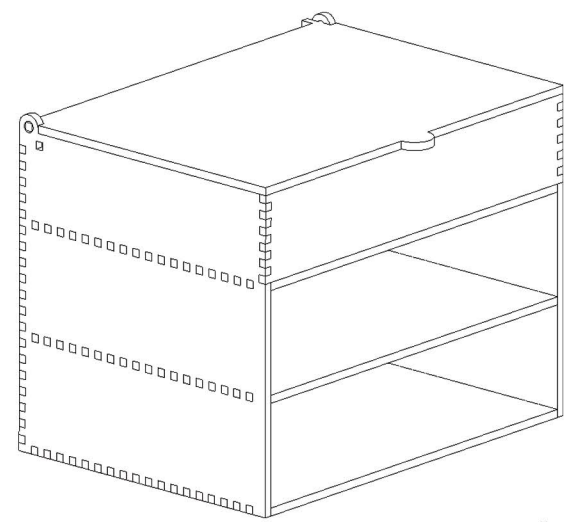

8. Slot piece H onto the D pieces and put to one side.

DRAWERS:

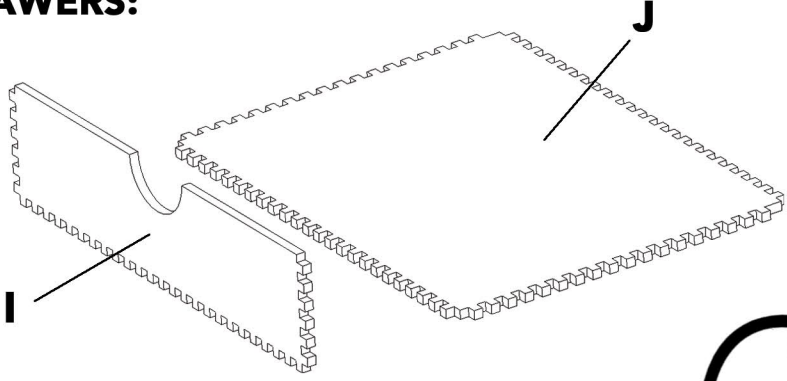

9. Slot pieces I and J together.

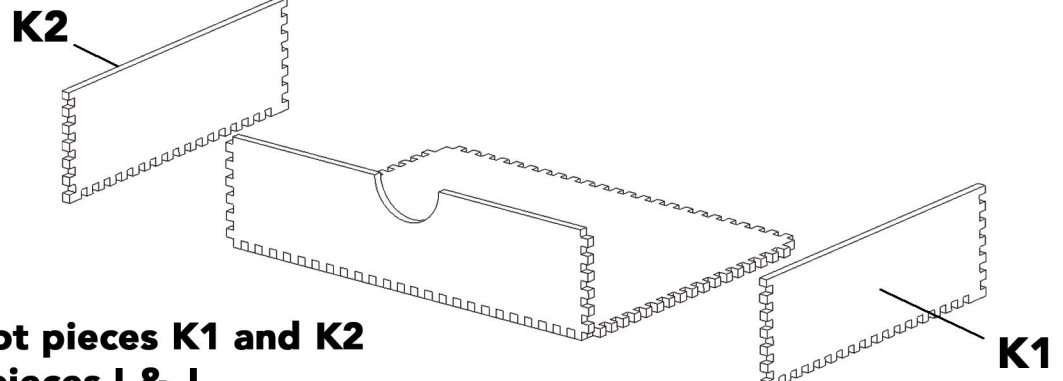

10. Slot pieces K1 and K2 onto pieces I & J.

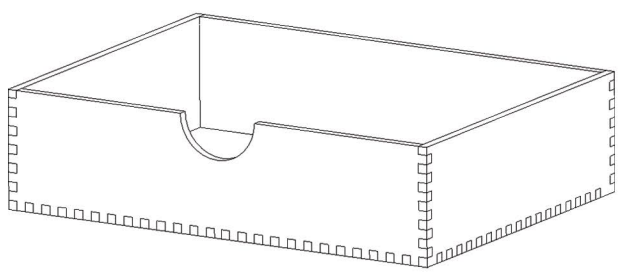

11. Slot piece L onto pieces J & K.

12. The draw is complete. Repeat steps 9,10 & 11 to construct the second drawer.

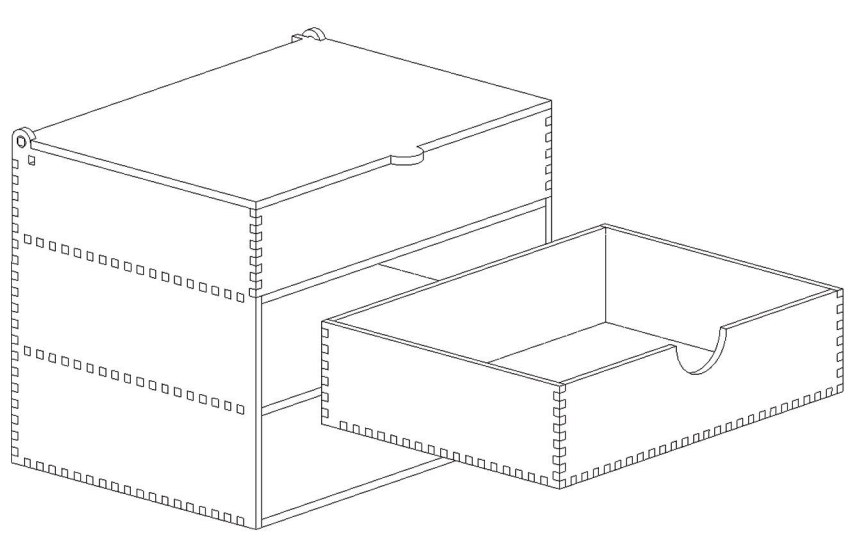

13. Slot the first drawer into the vanity case.

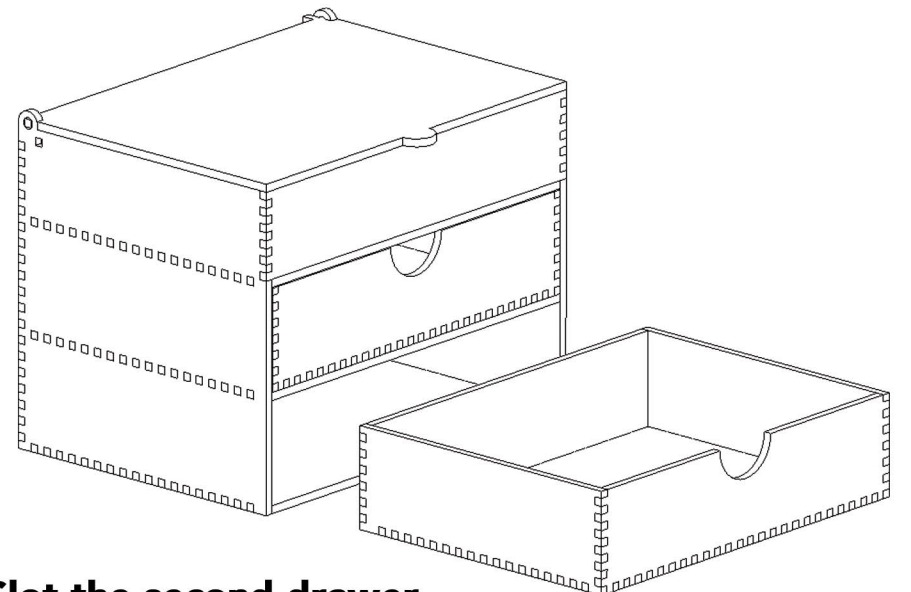

14. Slot the second drawer into the vanity case.

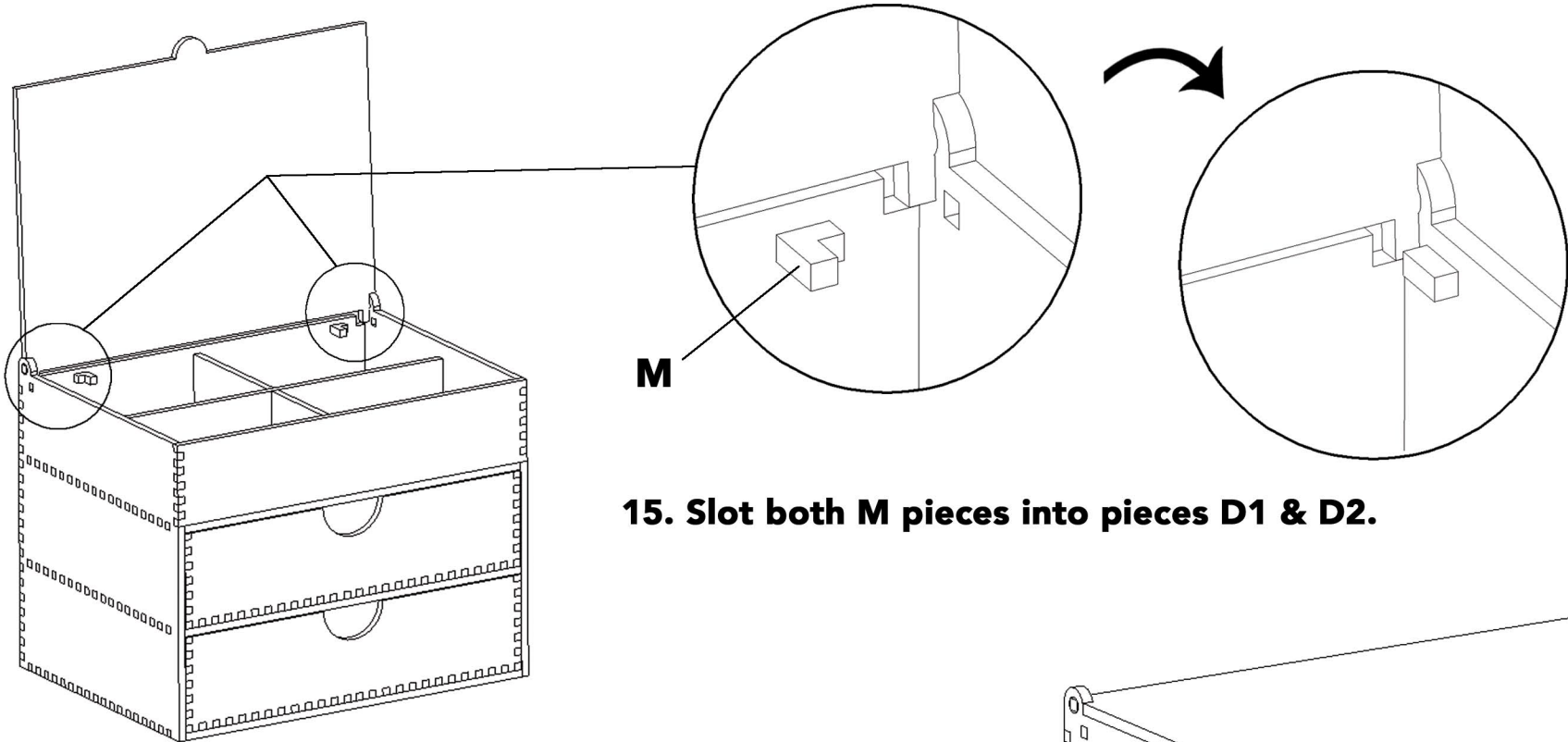

15. Slot both M pieces into pieces D1 & D2.

OPTIONAL MIRROR ATTACHMENT:

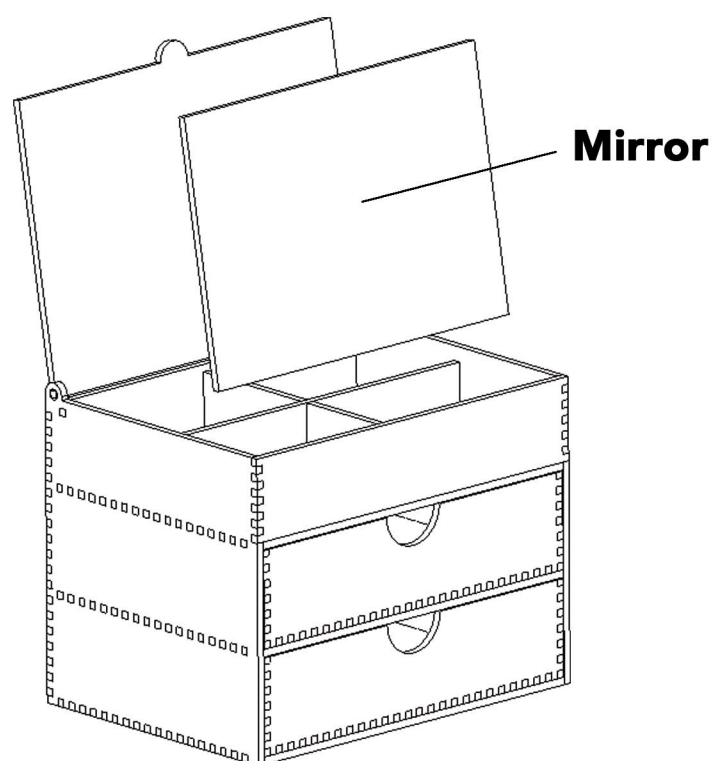

16. Add a small amount of strong adhesive glue to the back of the mirror and fix in the centre of the open vanity case lid (piece F).

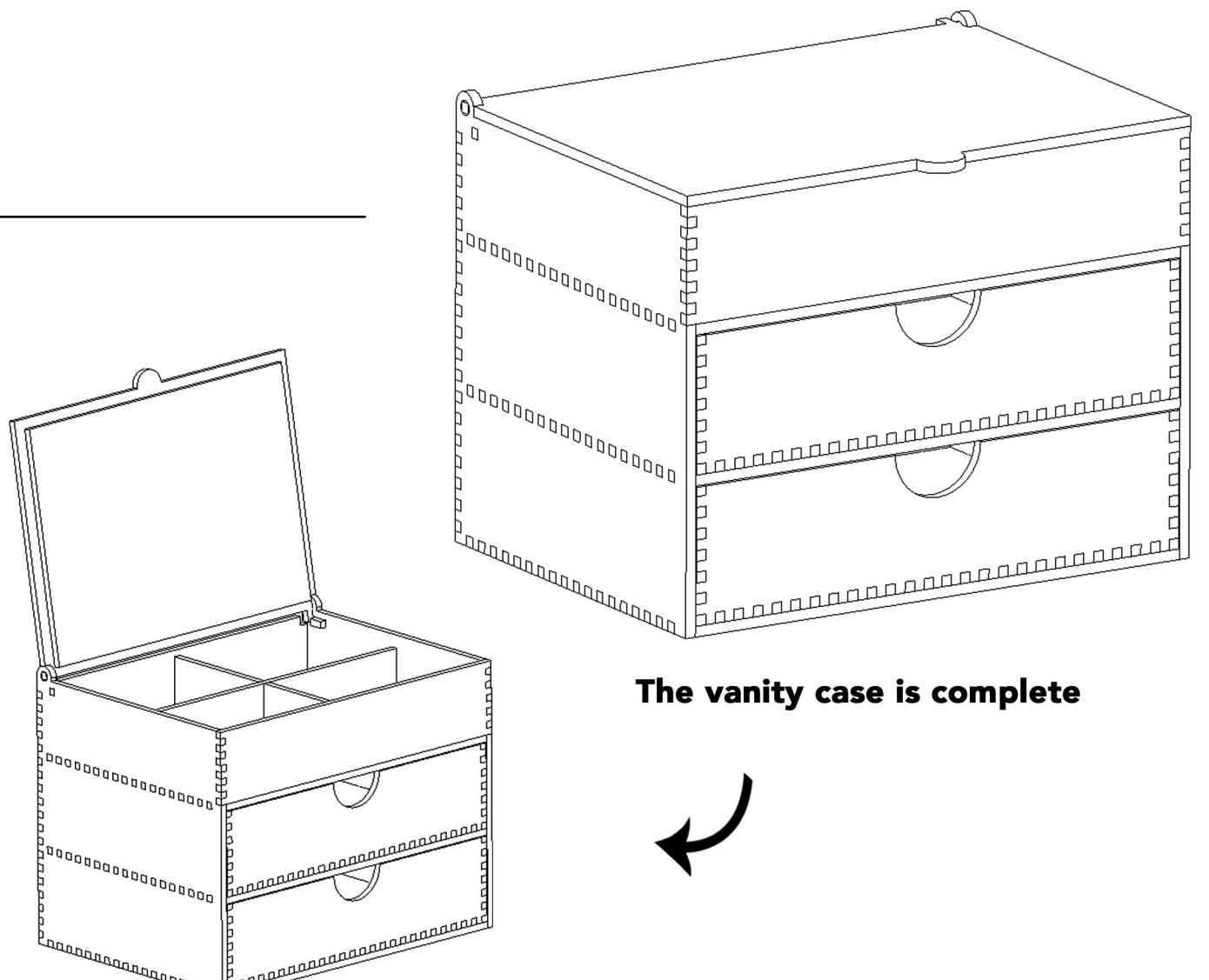

The vanity case is complete